

MATERIALS HANDLING

GIRDER CLAMPS

Enables chain blocks or hoists etc to be suspended from I-beams as a semi permanent lifting point.

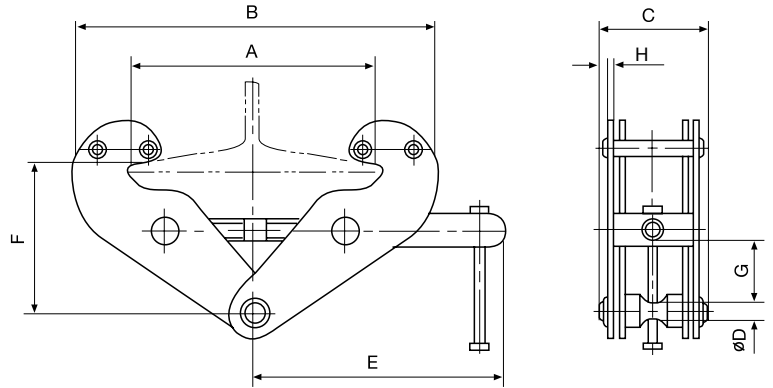

Specifications

Model	Rated Capacity (kg)	I Beam Width (mm)	Dimensions (mm)										Net Weight (kg)	
			A		B		C	H	E	F		G		D
			max	min	max	min				max				
LJ-1A	1000	75-220	260	180	360	64	5	215	102	155	25	22	4.5	
LJ-2A	2000	75-220	260	180	360	74	6	215	102	155	25	22	5.2	
LJ-3A	3000	80-320	354	235	490	103	8	260	140	225	45	24	10	
LJ-5A	5000	80-320	354	235	490	110	10	260	140	225	45	28	11.1	
LJ-10A	10000	90-320	365	320	505	120	12	280	170	235	50	40	20	

GIRDER PUSH TROLLEYS

A girder trolley provides a mobile suspension point to both support and move the load.



Specifications

Rated Capacity (kg)	I Beam Width (mm)	Net Weight (kg)
500	64-140	5.5
1000	64-132	8.9
2000	88-146	10.7
3000	100-154	24.3
5000	114-170	36.3
10000	124-180	83.3



Franklin Offshore Australia Pty Ltd

Tel +61 8 9410 6000 • sales@franklinoffshore.com.au